

# CO2 Recorder TR-76Ui Getting Started Guide

## Package Contents

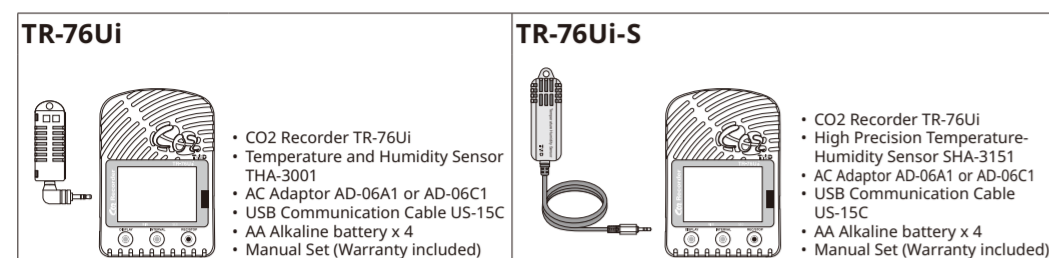

## T&D Corporation

https://tandd.com/  
© Copyright T&D Corporation. All rights reserved. 2023.11 16504640033 (16th Edition)

## Part Names and Basic LCD Display

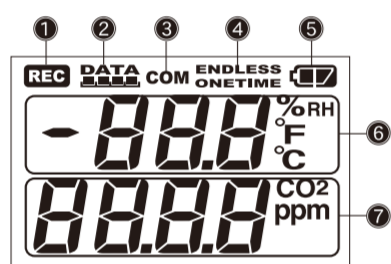
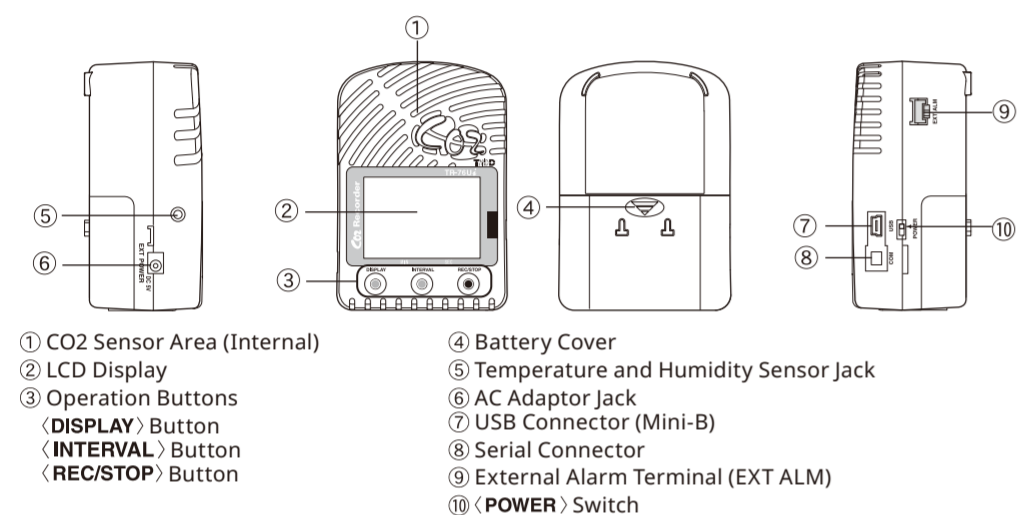

<b>① [REC] Mark</b>	Shows recording status ON: Recording in progress BLINKING: Waiting for programmed start OFF: Recording stopped
<b>② Data Scale</b>	At the beginning of every 2,000 readings the scale will be marked from left to right. Logging capacity is 8,000 readings.
<b>③ [COM] Mark</b>	Shows communication status but not displayed normally. ON: The unit is connected to a PC with a USB cable. RAPID BLINKING: The unit is in communication with the computer via USB.
<b>④ Recording Mode</b>	Recording mode settings can be made by using the software.
<b>Endless:</b>	Upon reaching the logging capacity of 8,000 readings, the oldest data will be overwritten and recording will continue.
<b>One Time:</b>	Upon reaching the logging capacity of 8,000 readings, recording will automatically stop and in the LCD the current measurement and the word "FULL" will alternately appear.
<b>⑤ Battery Mark</b>	Shows source of power and voltage level ON: Running on external power source BLINKING: Running on battery power OFF: No battery
<b>⑥ Current Temperature and Humidity Readings Area</b>	Shows the current readings for temperature (°C or °F) and humidity (%RH). Pressing the 〈DISPLAY〉 button will change the measurement item to be displayed. By using the software, the unit of temperature can be changed. This area is also used to display messages.
<b>⑦ Current CO2 Readings Area</b>	Shows the current readings for CO2 concentration (ppm). This area is also used to display messages.

## Notes about Operation

- ⚠ This product has been designed for use in normal living conditions, and is not suited for controlled environments such as a CO2 incubator. When measuring outdoors, avoid exposure to sunlight, dust, rain, or wind. Also make sure to use in the operating environment indicated in the specifications.
- ⚠ This product cannot measure CO or O2. Do not use the unit for purposes such as avoiding O2 deficiency, CO intoxication or any other health related purpose.
- ⚠ For one to two weeks after installation of the TR-76Ui, CO2 concentration measurements may fluctuate suddenly. This is due to the normal operation of Auto Calibration and is not a malfunction of the unit.
- ☀ Do not use or store the unit in areas exposed to direct sunlight and abrupt changes in temperature.
- 💧 Do not allow the unit to become wet. Do not use or store the unit in places where condensation occurs.
- 🚬 To help prevent deterioration of the unit, do not use or store the unit in areas exposed to cigarette smoke, corrosive, explosive or organic gases or dust in the air.
- 🔪 Do not expose the unit to a strong impact. This will adversely affect measurement accuracy and may cause the case to break resulting in bodily injury.
- ⚠ The measurement accuracy of the CO2 sensor can not be guaranteed for CO2 concentrations of 5,000ppm or more.
- ⚠ The Warning Monitoring function provided in the TR-76Ui is for informational purposes only. By clicking "I Agree" button you confirm your understanding that it is not to be relied upon for human health or safety.

## Button Operations

- ⚠ Upon the start of recording, all previously recorded data in the TR-76Ui will be deleted.
- ⚠ If "Button Lock" has been set to ON in the CO2 Recorder for Windows, the operational buttons will not be active.

### 〈REC/STOP〉 Button: Starting and Stopping Recording

- Starting Recording**  
Press the 〈REC/STOP〉 button for about two seconds until the [REC] mark appears on the display.
- It is possible to start recording even while waiting for a programmed recording to start.
- Stopping Recording**  
Press the 〈REC/STOP〉 button for about two seconds until the [REC] mark disappears from the display.

### 〈DISPLAY〉 Button: Changing the LCD Display Pattern

- It is possible to change the current readings display for temperature and humidity (upper row). CO2 concentration (lower row) is always displayed.
1. With each pressing of the 〈DISPLAY〉 button, the display on the upper row will change as follows: temp/humidity (alternating) → temp (fixed) → humidity (fixed)
  2. When the desired display pattern appears, stop pressing the button.

### 〈INTERVAL〉 Button: Checking Recording Interval

- It is possible to check the recording interval during recording or while waiting for a programmed recording to start.
1. By pressing the 〈INTERVAL〉 button for about two seconds, the currently set recording interval will appear on the LCD display.
  2. If no operation is carried out after the recording interval has been displayed, the current measurement readings will return to the LCD display.

### 〈INTERVAL〉 Button: Changing the Recording Interval Setting

- Recording interval settings cannot be changed while a recording session is in progress.
1. Stop recording.
  2. Press the 〈INTERVAL〉 button for about two seconds to display the currently set recording interval on the LCD screen.
  3. With each pressing of the 〈INTERVAL〉 button the recording interval time will change; stop pressing the button when the desired interval appears.
  4. Restart the recording session.

Upon the start of recording, all previously recorded data in the TR-76Ui will be deleted.

### When [----] appears in the following:

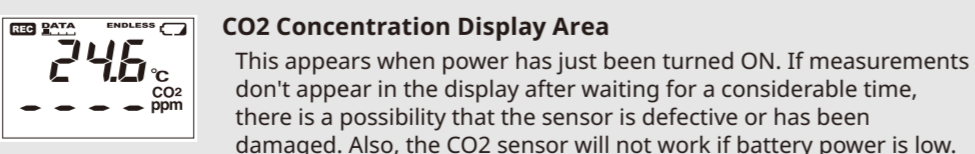
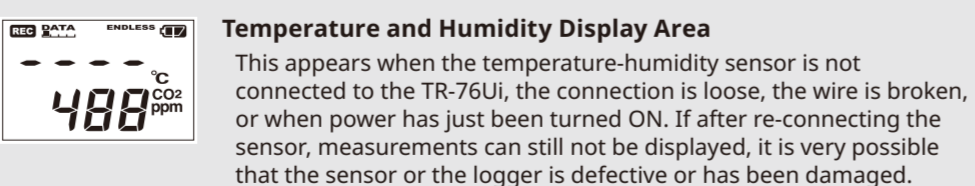

- Measurement and recording will continue in this situation, so battery power will be consumed.

## Messages and Display on the LCD

### Settings Messages



#### Button Lock

When "Button Lock" has been set to ON in CO2 Recorder for Windows, operational buttons are not active.



#### Memory Full

When recording mode has been set to "One Time" and the unit reaches its logging capacity of 8,000 readings, the measurement and the message [FULL] will alternately appear in the LCD. Stop recording and download the recorded data before re-starting recording.

- When this happens, measurement will continue so battery power will be consumed.

## Setting up the TR-76Ui

- ⚠ Make sure to install the software before connecting the TR-76Ui to your PC.

### Connect the Temperature and Humidity Sensor

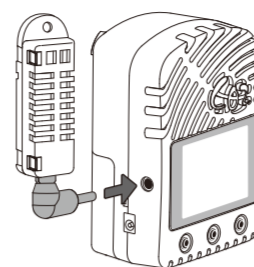

### Turn On the Power

#### AC Adaptor

When measuring and recording over long periods of time, please use a supplied AC adaptor.

#### Four AA Alkaline Batteries

Keeping batteries in the unit allows a backup source of power \* for when and if electrical power is cut from the AC adaptor. If running on only batteries, the estimated battery life is about two days.

- \* Leaving alkaline batteries in the unit for a long period of time may cause battery leakage and corrosion. When using as a backup source, we recommend that you change the batteries every few years.

#### Turn On the 〈POWER〉 Switch

After setting up the power supply, turn on the 〈POWER〉 Switch.

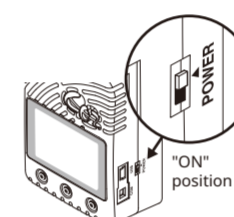

#### Warm-up Time for CO2 Sensor

After switching on the unit, it will take about one minute to display the normal CO2 concentration.

### Install the Batteries

- ⚠ If battery power is lost, all recorded data stored in the unit will be erased. Do not leave the unit without batteries.

1. Remove the battery cover from the back of the unit.

- ① While pressing down on the triangular mark, slide the cover to the bottom of the unit.

- ② Lift off the cover.

2. Insert the batteries.

- Make sure to use four new batteries of the same kind.
- Make sure not to mistake + / -.
- Do not insert or change batteries with wet hands.
- Be sure to completely close the cover.

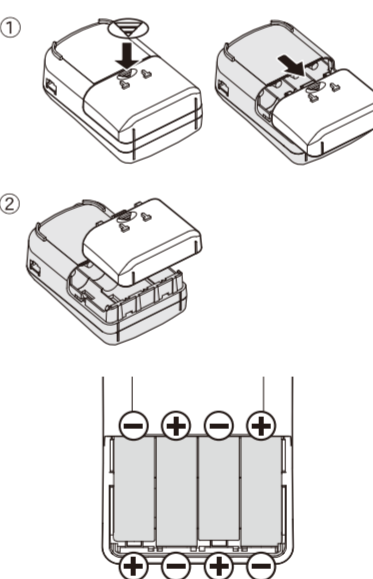

## Notes on Special Functions

### Getting Ready for Using the Warning Monitoring Function

It is possible to connect an external device such as siren or lamp to the TR-76Ui. Please make sure to check specification details of the external alarm terminal before purchasing or getting an external device ready for connection.

#### Upper and Lower Limit Settings

To use the warning monitoring function, go to the [Start Recording] tab in the CO2 Recorder for Windows and make settings for Upper and Lower Limits and Judgment Time. When the measurement exceeds one of the set upper and lower limits, the TR-76Ui will turn ON the external alarm terminal. Upon a warning, the measurement value on the display will also flash.

## Interpreting the Battery Mark

### Checking the Power Supply Condition

Whether the battery mark is "blinking" or "on" indicates the source of power.

#### BLINKING (Running on battery):

The battery mark will blink on the LCD display when measuring and recording by battery power.

Mark blinks when running on battery power.



#### ON (Running on external power):

The battery mark will be on when measuring and recording by AC adaptor power.

### Checking the Battery Level

The battery level will be shown in three stages as below.

- ① **Battery Power - OK**
- ② **Battery Power - Getting Low**  
Please change the batteries as soon as possible.
- ③ **Battery Power - Too Low**  
Battery power is too low to carry out measurement and recording of CO2 concentration.

- When running on batteries only, it will take about 24 hours to go from Stage ① to ② and another 24 hours from Stage ② to ③.

#### ④ Sleep Mode (stopping measurement and recording)

- After Stage ③, if the battery is not changed but it remains in use, the unit will enter sleep mode and stop measurement and recording in order to protect recorded data until this point.
- To continue recording, it is necessary to change the batteries before the unit enters sleep mode.
  - If the unit is already in sleep mode, download the recorded data into the PC before re-starting recording.

#### ⑤ Erasing recorded data

If the battery is further left unchanged, the display will automatically shut off and all previously recorded data will be lost.

## Removing the Batteries during Recording

1. If the batteries are removed when running on battery power only, the unit will start a sixty-second countdown.
2. To continue recording, before the countdown comes to an end, insert new batteries or connect the AC adaptor to supply power.
3. If power is not supplied within 60 seconds, the unit will enter sleep mode.

## Turning Off the 〈POWER〉 Switch

- ⚠ During recording or when the "Button Lock" is set to ON in the CO2 Recorder for Windows, the power cannot be turned off even by pressing the 〈POWER〉 Switch.

1. Stop recording.
2. Turn off the 〈POWER〉 Switch.

### Standby Power

If the TR-76Ui is connected to an AC adaptor, standby power will be supplied even after turning off the 〈POWER〉 switch, allowing the CO2 sensor to continue operation.

## About the External Alarm Terminal (EXT ALM)

Enabling Warnings	Warning Output (Enable / Disable)	Warning Output (OUT)	Internal Pull-up: 3V 100kΩ Maximum Input Voltage: 30V
①	Warning Output (Enable / Disable)		
②	GND		
③	Output Terminal (Warning Output)		Open Drain Output Voltage when OFF: DC less than 30V Current when ON: less than 0.1A Resistance when ON: 15Ω
④	GND		

The connection between ① and ② decides whether Warning Output is enabled or disabled. If a warning condition occurs while Warning Output is enabled, a connection between ③ and ④ will be established and a warning will be output.

### Alarm Connection Cable

The optional alarm connection cable (AC0101) is available. Please contact your local distributor for purchase.

Distributor List: https://tandd.com/purchasing/

# Using the Software

## STEP 1 Install the Software

For installation of the software, it is necessary to have Administrator (Computer Administrator) rights.

Download CO2 Recorder for Windows and T&D Graph from the T&D Website and install to your PC.

\* Do not connect a TR-76Ui to your computer until the software has been installed.

<https://tandd.com/software/>

After installation, CO2 Recorder for Windows and T&D Graph will appear in the Windows Start Screen or Start Menu.

- If you have no internet access or prefer to install using a software DVD, "T&D Software SO-TD1" is also available as an option.
- Please contact your distributor for details. (<https://tandd.com/purchasing/>)
- For details about operations please see the "Help" menu in the software.

## STEP 2 Connect the TR-76Ui to a PC

- Connect the device with the supplied USB cable to your computer. The USB driver installation will start automatically.
  - It is not necessary to connect AC adaptor at this point.
- Open CO2 Recorder for Windows and confirm that the TR-76Ui icon appears in the main window.

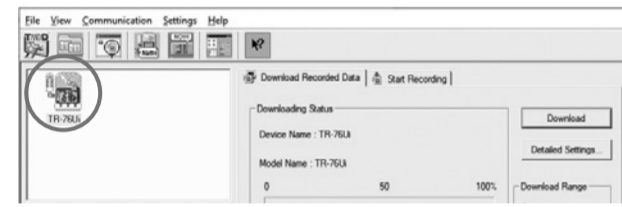

- If the icon does not appear, please check whether the USB driver has been properly installed. (Refer to [F6] Help for Unit Recognition Failure)

## STEP 3 Make Atmospheric Pressure Correction Settings

Measurement results of CO2 concentration are affected by atmospheric pressure. When high measurement accuracy is required, we recommend that Atmospheric Pressure Correction be carried out before a recording session is started.

- From the [Settings] Menu, select [Atmospheric Pressure Correction] to open the settings window.

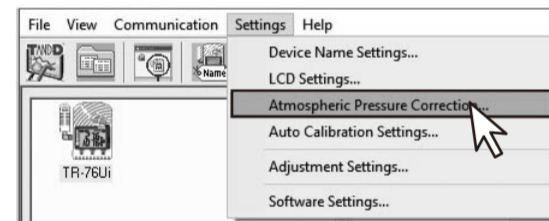

### Enter Atmospheric Pressure at Measurement Location:

Directly enter the pressure (hpa) in the [Atmospheric Pressure] field.

### Calculate Atmospheric Pressure from Altitude:

This setting can also be made by having the software calculate the estimated pressure at the altitude (meters) entered by the user.

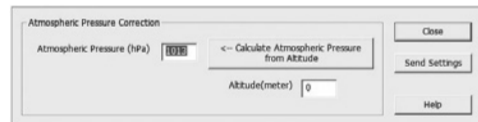

- Click the [Send Settings] button to transmit the settings to the TR-76Ui.

## STEP 4 Make Settings and Start Recording

Upon the start of recording, all previously recorded data in the TR-76Ui will be deleted.

- Make recording settings in the [Start Recording] tab window.

### Recording Start Date and Time

**Programmed Start:** Recording will begin on the set date and time. As the current date and time of your computer are used, make sure that your computer clock settings are correct.

**Immediate Start:** Recording will start when the [Start Recording] button is clicked.

### Recording Mode

**One Time:** Upon reaching the logging capacity of 8,000 readings, recording will automatically stop.

**Endless:** Upon reaching the logging capacity of 8,000 readings, the oldest data will be overwritten and recording will continue.

### Recording Interval

There are 15 choices for the recording interval. Below are some examples of recording interval and maximum recording time.

1 second	(2 hr 13 min 20 sec)	10 minutes	(55 days 13 hr 20 min 00 sec)
30 seconds	(2 days 18 hr 40 min 00 sec)	15 minutes	(83 days 8 hr 00 min 00 sec)
1 minute	(5 days 13 hr 20 min 00 sec)	30 minutes	(166 days 16 hr 00 min 00 sec)
5 minutes	(27 days 18 hr 40 min 00 sec)	60 minutes	(333 days 8 hr 00 min 00 sec)

- Click the [Start Recording] button to transmit the settings to the TR-76Ui.

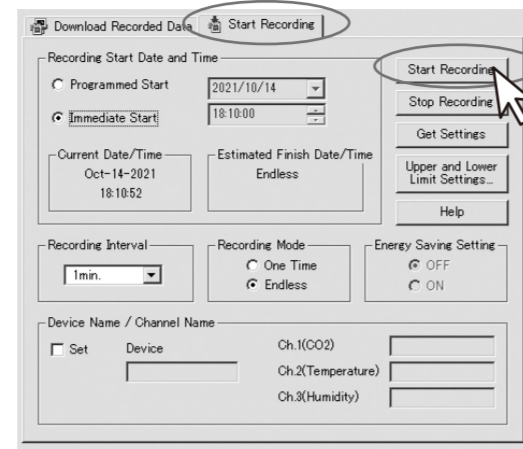

- Disconnect the TR-76Ui from the PC and place in the desired measurement location.

## STEP 5 Download Recorded Data to a PC

Even after downloading recorded data, the data will remain in the TR-76Ui.

- Connect a TR-76Ui to your PC and open CO2 Recorder for Windows.
- In the [Download Recorded Data] tab window, click the [Download] button.

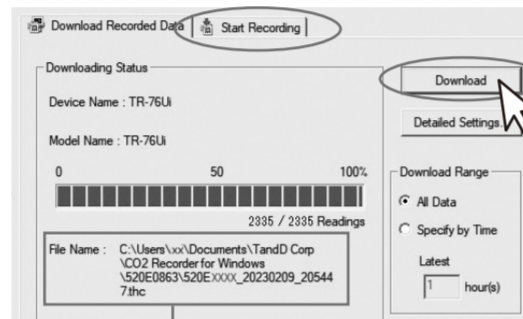

Here you can check the storage location and file name for the recorded data.

- When a completion message appears after downloading, click the [OK] button to view the graph for that data.

### Storage Location of Recorded Data and File Name (Default Settings)

Documents (or My Documents)\TandD Corp\CO2 Recorder for Windows\Serial No.(folder)\Serial No.+ Downloading Date and Time.thc

\* Serial No. can be found on the sticker attached to the logger.



## STEP 6 View and Print Graphs

### Viewing Saved Data in Graph Form

- Open T&D Graph.
- From the [File] menu, click [Open].
- Select the desired file, and click the [Open] button to view the graph for that data.

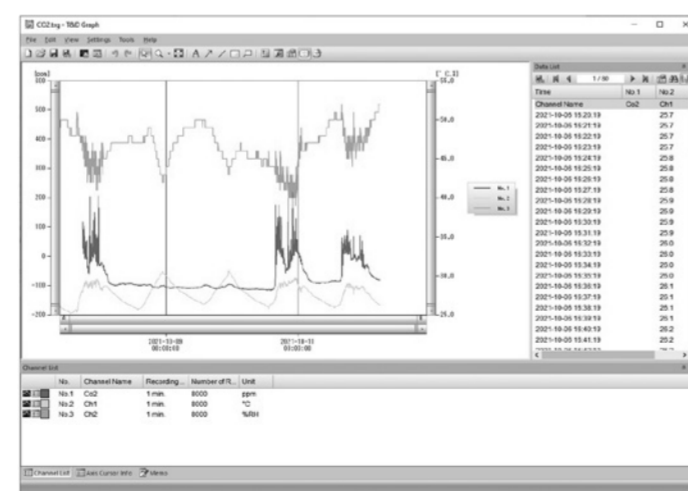

## Printing the Graph

- While the graph is open, make any desired adjustments to the graph enlargement, position and aspect ratio to be reflected in the printed graph.

Graphs will be printed using the resolution and aspect ratio settings made for the Graph Display Area in Step 1 above. If you wish to change the resolution and/or aspect ratio, go back to Step 1 and make further adjustments based on the preview image.

- From the [File] menu, click [Print Graph].
- By selecting the options on the toolbar in the Print Preview window, you can adjust the paper orientation, margin, items to be printed, etc. The graph title, items to be printed, and margin can be set in [Page Setup].
- Click the [Print] button.

## Opening Data using Spreadsheet Software

It is possible to convert recorded data to a text file (CSV format) which can be read by common spreadsheet software.

- While the graph is open, click [Save in CSV Format] in the [File] menu.
- Specify the storage location, file name, and file type, then click the [Save] button.

- For operational details of the T&D Graph, refer to the software Help.
- Note however that the text format data cannot be read by T&D graph applications.
- For operational details of the spreadsheet software, refer to the software manual or help.

## Tips Auto Calibration Function for CO2 Sensor

The CO2 sensor has a calibration function (auto/manual calibration) to compensate for sensor drift that can occur over time.

Auto calibration is designed to enable long-term accurate measurements by gradually adjusting the lowest measured CO2 concentration over a 180 hour period, to the global average concentration (atmospheric CO2 level of around 400 ppm). Please turn off auto calibration when continuously measuring in an environment where the CO2 concentration is always high or low.

- The factory default setting for auto calibration is ON.
- The setting can be changed from the CO2 Recorder for Windows [Settings] menu - [Auto Calibration Settings]. For the operation procedures including manual calibration, refer to the [Operation Guide] - [Available Settings].

## For more detailed information

### Operation Guide:

Operation Guide contains detailed information about basic settings as well as details about advanced settings for many useful functions. Access it from the Start Screen/Menu or from the [Help] button in the application window.

### Help for Unit Recognition Failure:

[Help for Unit Recognition Failure] contains detailed information about installing and checking the USB driver as mentioned in [Using the Software : STEP 2]. Access is via the [Help] menu in CO2 Recorder for Windows.

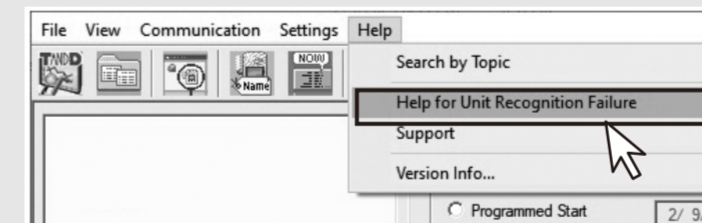

## Specifications

	TR-76Ui		TR-76Ui-S	
Temperature-Humidity Sensor (External)				
Sensor	THA-3001		SHA-3151(High-Precision Type)	
	Thermistor	Polymer Resistance	Thermistor	Polymer Resistance
Measurement Channels	Temperature 1ch	Humidity 1ch	Temperature 1ch	Humidity 1ch
Units of Measurement	°C, °F	%RH	°C, °F	%RH
Measurement Range (*1)	0 to 55 °C	10 to 95 %RH	-25 to 70 °C	0 to 99 %RH (*2)
Accuracy	±0.5 °C	±5 %RH at 25 °C, 50 %RH	±0.3°C at 10 to 40 °C ±0.5°C at 15 to 35 °C, 30 to 80 %RH	±2.5 %RH at 15 to 35 °C, 30 to 80 %RH
Measurement Resolution	0.1 °C	1 %RH	0.1 °C	0.1 %RH
Responsiveness	Response Time (90%): Approx. 7 min.		Response Time (90%): Approx. 7 min.	

CO2 Sensor (Internal)	
Sensor	NDIR
Measurement Channels	CO2 Concentration 1ch
Units of Measurement	ppm
Measurement Range	0 to 9,999 ppm
Accuracy	±(50 ppm + 5 % of reading) at 5,000 ppm or less (*3)
Measurement Resolution	Minimum of 1 ppm
Responsiveness	Response Time (90%): Approx. 1 min.

Unit Specifications	
Logging Capacity	8,000 data sets (One data set consists of readings for all channels in that type of unit.)
Recording Interval	Select from 15 choices: 1, 2, 5, 10, 15, 20, 30 sec. or 1, 2, 5, 10, 15, 20, 30, 60 min.
Recording Mode	Endless (Overwrite oldest data when capacity is full) or One Time (Stop recording when capacity is full)
Communication Interfaces	USB Communication (Mini-B connector) Serial Communication (*4)
External Alarm Terminal (*5)	Output Terminal: Open Drain Output (Voltage when OFF: DC less than 30V / Current when ON: less than 0.1A / Resistance when ON: about 15Ω)
Power	AC Adaptor (AD-06A1 or AD-06C1), AA Alkaline LR6 Battery x 4
Battery Life	Approx. 2 days (batteries only without AC adaptor) (*6)
Dimensions	H 96 mm x W 66 mm x D 46 mm (excluding protrusions and sensor)
Weight	Approx. 120 g
Operating Environment	Temperature: 0 to 45 °C, Humidity: 90 %RH or less (no condensation)
Initial Settings	Recording Mode: Endless, Recording Interval: 10 min.
Software (*7)	PC Software (Windows) CO2 Recorder for Windows, T&D Graph

- \*1: Make sure to use the data logger within the operating environment as listed in the specifications.
- \*2: When continually used in environments with temperatures above 60°C, accuracy of humidity measurements will decrease over time. Also, humidity cannot be measured at temperatures below -20°C.
- \*3: Stated value is the measurement accuracy of the CO2 sensor when Auto Calibration is operating properly. A change in atmospheric pressure directly influences the reading of CO2, which can cause measurement errors; a decrease in pressure by 10 hPa results in a relative decrease in CO2 by 1.6%. In such a case, we recommend carrying out the "Atmospheric Pressure Correction" function found in CO2 Recorder for Windows.
- \*4: Customers wishing to write their own software, please contact your local distributor for the serial communications protocol specifications. (Note: Optional serial communication cable TR-07C is also required.)
- \*5: In order to use the external alarm terminal, please purchase the optional alarm connection cable (AC010).
- \*6: Battery life varies depending upon multiple factors including ambient temperature, recording interval, frequency of communication, and battery performance. All estimates are based on operations carried out with a new battery and are in no way a guarantee of actual battery life.
- \*7: Free software download and information on OS compatibility is available on the Software page of our website at <https://tandd.com/software/>.

## Cautions about using the Temperature-Humidity Sensors

- If extremely severe temperature changes occur, the humidity measurements may appear abnormal. Once the sensor's temperature becomes stable, the measurements will return to normal.
- Do not connect the sensor to any data logger other than those specified by T&D Corporation.
- Do not expose the sensor to a strong impact. This may adversely affect measurement accuracy and cause damage or malfunction.
- When the sensor is not to be used for a long period of time, please store it at normal temperature and humidity.
- Do not allow the sensor to become wet. If the sensor gets wet, immediately remove it from the unit.
- Do not use the sensor on the human body.
- Do not expose to condensation, dampness, corrosive gases, or organic solvents.
- Continued use may cause a decrease in the sensor's accuracy and sensitivity even under normal operational conditions. If the sensor is being used in a bad environment (smoky or dusty places) it may be necessary to change the sensor sooner.
- The SHA-3151 is not water resistant. If the sensor gets wet, immediately remove the sensor from the unit and wipe it with a clean cloth as soon as possible. Then allow the sensor to dry in normal room temperature before using it again.
- When using the THA-3001/3151 in an environment where the humidity is under 30%RH, the measurements may sometimes fluctuate. This is not abnormal.

## Compliance Information

### FCC Statement

This device complies with Part 15 of the Federal Communications Commission (FCC) rules. Operation is subject to the following two conditions: (1) This device may not cause harmful interference, and (2) this device must accept any interference received, including interference that may cause undesired operation.

Note: This equipment has been tested and found to comply with the limits for a Class B digital device, pursuant to Part 15 of the FCC Rules. These limits are designed to provide reasonable protection against harmful interference in a residential installation. This equipment generates, uses and can radiate radio frequency energy and, if not installed and used in accordance with the instructions, may cause harmful interference to radio communications. However, there is no guarantee that interference will not occur in a particular installation.

If this equipment does cause harmful interference to radio or television reception, which can be determined by turning the equipment off and on, the user is encouraged to try to correct the interference by one or more of the following measures:

- Reorient or relocate the receiving antenna.
- Increase the separation between the equipment and receiver.
- Connect the equipment into an outlet on a circuit different from that to which the receiver is connected.
- Consult the dealer or an experienced radio/TV technician for help.

Changes or modifications not expressly approved by the party responsible for compliance could void the user's authority to operate the equipment.

WessexPower  
Solutions for High-tech Instrumentation  
[www.wessexpower.co.uk](http://www.wessexpower.co.uk)

LS Technology  
E-commerce Instrumentation  
[www.loggerhop.co.uk](http://www.loggerhop.co.uk)

Telephone +44(0)1929 459 459      Email [sales@WPLS.co.uk](mailto:sales@WPLS.co.uk)